

# COSORI®

## User Manual

### Pioneer 5-Tray Food Dehydrator

Model: CFD-N051-W

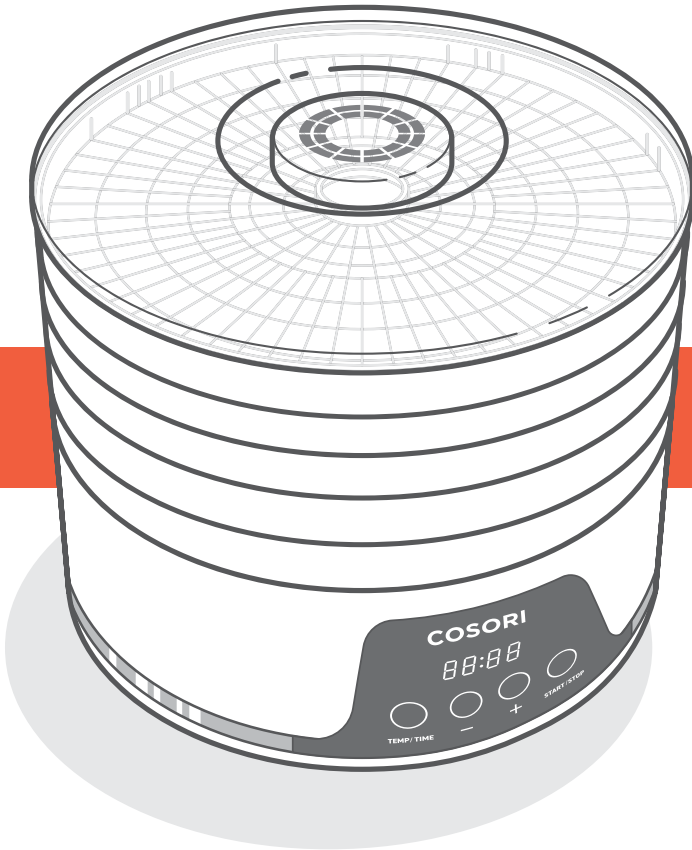

#### Questions or Concerns?

Mon–Fri, 9:00 am–5:00 pm PST/PDT  
support@cosori.com | (888) 402-1684

 *Thank you for  
your purchase!* 

(We hope you love our new food dehydrator as much as we do.)



*join*

the Cosori Cooks Community on Facebook  
[facebook.com/groups/cosoricooks](https://facebook.com/groups/cosoricooks)



*enjoy*

weekly, featured recipes  
*made exclusively by our in-house chefs*



*explore*

our recipe gallery  
[www.cosori.com/recipes](http://www.cosori.com/recipes)



## CONTACT OUR CHEFS

Our helpful, in-house chefs are ready to assist you with any questions you might have!

**Email:** [recipes@cosori.com](mailto:recipes@cosori.com)

**Toll-Free:** (888) 402-1684

M-F, 9:00 am–5:00 pm PST/PDT

On behalf of all of us at Cosori,

*Happy cooking!*

## Table of Contents

|                                 |    |
|---------------------------------|----|
| Package Contents                | 3  |
| Specifications                  | 3  |
| Important Safeguards            | 4  |
| Getting to Know Your Dehydrator | 6  |
| · Food Dehydrator Diagram       | 6  |
| Control Panel                   | 7  |
| Before First Use                | 7  |
| Using Your Dehydrator           | 8  |
| · Operation                     | 8  |
| · Overheat Protection           | 9  |
| · Tips                          | 9  |
| Care & Maintenance              | 10 |
| Troubleshooting                 | 11 |
| Warranty Information            | 13 |
| Customer Support                | 14 |

## Package Contents

- 1 × Pioneer 5-Tray Food Dehydrator
- 5 × Trays
- 1 × Recipe Book
- 1 × User Manual

## Specifications

|                          |   |
|--------------------------|---|
| <b>Power Supply</b>      | AC 120V, 60Hz                           |
| <b>Rated Power</b>       | 350W                                    |
| <b>Temperature Range</b> | 95°–165°F / 35°–73°C                    |
| <b>Product Size</b>      | 12 × 12 × 9 in /<br>30.8 × 30.8 × 23 cm |

# READ AND SAVE THESE INSTRUCTIONS

## IMPORTANT SAFEGUARDS

---

Always follow basic safety precautions when using your dehydrator.  
Read all instructions.

### General Safety

- **Do not** touch hot surfaces.
- **Do not** immerse cord, plug, or base in water or other liquid.
- Closely supervise children near the dehydrator.
- Unplug when not in use, and before cleaning. Allow to cool before putting on or taking off parts.
- **Do not** use dehydrator if it is damaged, not working, or if the cord or plug is damaged. Contact **Customer Support** (page 14).
- Using third-party parts or accessories may cause injuries.
- **Do not** use outdoors.
- **Do not** place on a stove, near gas or electric burners, or in a heated oven.
- Be extremely cautious when moving the dehydrator if it contains hot liquids, and when removing trays if they contain hot liquids.
- **Do not** clean base with metal scouring pads. Metal fragments can break off the pad and touch electrical parts, creating a risk of electric shock.
- **Do not** run the dehydrator for more than 48 hours at a time. After 48 hours, unplug and allow to cool for 2 hours before using again.
- **Do not** allow liquids to drip into the vents in the base of the dehydrator.
- Not for commercial use. Household use **only**.
- **Only** use the dehydrator as directed in this manual.

# IMPORTANT SAFEGUARDS (CONT.)

---

## Power & Cord

- **Do not** let cord (or any extension cord) hang over the edge of a table or counter, or touch hot surfaces.
- This dehydrator has a polarized plug (one prong is wider than the other), which fits into a polarized outlet only one way. If the plug does not fit, reverse the plug. If it still does not fit, **do not** use the plug in that outlet. **Do not** alter the plug in any way.
- This dehydrator uses a short power-supply cord to reduce the risk of entangling or tripping. Use extension cords with care.
- The marked electrical rating of an extension cord should be at least as high as the rating of the dehydrator (page 3).
- Your dehydrator should **only** be used with **120V, 60Hz** electrical systems. **Do not** plug into another type of outlet. If you try to use the dehydrator with a higher voltage, the display will show an E4 error.

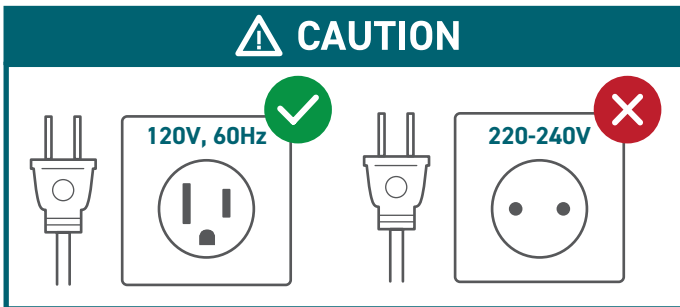

# GETTING TO KNOW YOUR DEHYDRATOR

Your Cosori Dehydrator features an automatic fan, which circulates warm air to evenly dry food. Dried foods are a great treat to snack on because they keep almost all their nutritional value and flavor. Dehydrating is the perfect way to preserve snacks, fruit, vegetables, bread, and even flowers.

## Food Dehydrator Diagram

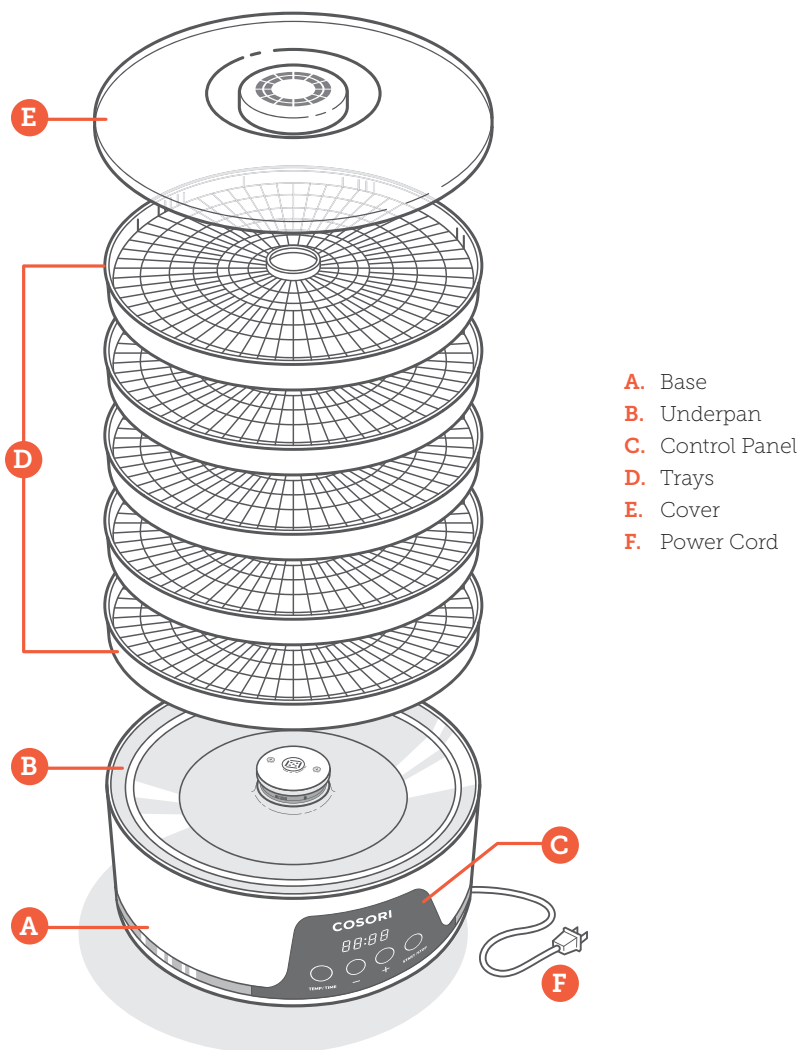

# CONTROL PANEL

---

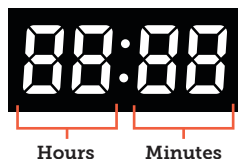

## Controls

- To start or stop the dehydrator, press **START/STOP**.
- To change the temperature, press **TEMP/TIME** once, then press **+** or **-**.
- To change the time, press **TEMP/TIME** a second time, then press **+** or **-**.

## Sounds

- To turn sounds on/off, wait for the display to show "--:--", then press and hold **+** for 5 seconds until the dehydrator beeps 1 time.

# BEFORE FIRST USE

---

## Setting Up

1. Remove all packaging from your dehydrator and its accessories. Make sure all package contents are included (see page 3).
2. Clean the base and trays with a moistened cloth.  
**Note:** The trays can be washed in the top rack of a dishwasher **only** if you remove them before the drying cycle starts. **Do not** wash the base in a dishwasher. **Do not** immerse the base in water.
3. Place the dehydrator base on a solid, level surface. Plug in. Stack the drying trays on top of the base.
4. Run the dehydrator for 30 minutes at any temperature, without adding any food. Make sure that the room has sufficient ventilation, in case the dehydrator produces any smoke or smells. This is normal.
5. Rinse the trays in water. Dry all parts.

**Note:** You only need to do this the first time you use the dehydrator.

# USING YOUR DEHYDRATOR

## Operation

**Note:** Use the dehydrator in a warm, dry room. Depending on humidity in the air and moisture in the food, dehydration time may vary.

1. Place food on trays. The trays can hold up to 1.1 lb (0.5 kg) of food. Place food on the bottom tray first, and use the top tray last. Be careful not to overload the trays.

**Note:** The trays can be rotated to provide more spacing between each tray. [Figure 1.1]

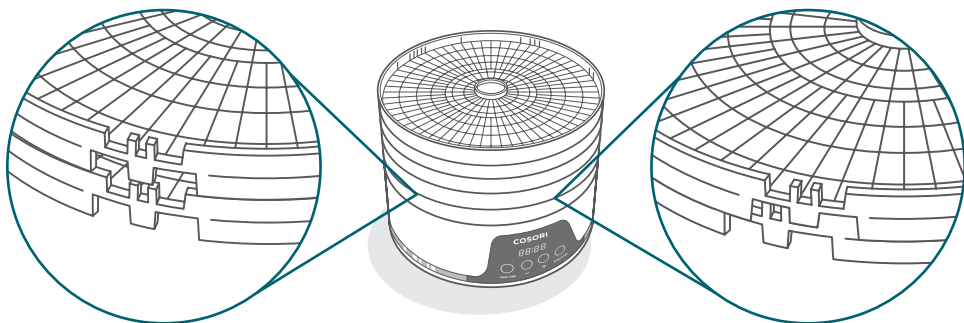

Figure 1.1

2. Plug in. The dehydrator will beep, and the display will show "88:88". The dehydrator will switch to standby mode after 3 seconds, and the display will show "--:--".
3. Press **TEMP/TIME** to choose temperature. The temperature will blink on the display, and the **+** and **-** buttons will light up. Use **+** or **-** to change the temperature (95°–165°F).  
**Note:** Temperature changes in 1°F increments. Press and hold **+** or **-** to change the temperature rapidly.
4. Press **TEMP/TIME** again to choose time. The time will blink on the display, and the **+** and **-** buttons will light up. Use **+** or **-** to change the time (0:30–48:00).  
**Note:** Time changes in 30 minute increments. Press and hold **+** or **-** to change the time rapidly.
5. Press **START/STOP** to start dehydrating. The dehydrator will start heating. **START/STOP** will stay lit, and the other buttons will turn off. Temperature and time will cycle on the display every 3 seconds.  
**Note:** If you press **START/STOP** again to stop dehydration, the timer countdown will reset and the dehydrator will go into standby mode.
6. Optionally, you can change the time and temperature at any time by pressing **TEMP/TIME**.
7. When the timer finishes, the display will show "End" and heat will turn off. The dehydrator will beep 5 times, and the fan will continue running for 5 seconds before stopping.  
**Note:** The dehydrator will always remember your previous temperature and time settings.



# USING YOUR DEHYDRATOR (CONT.)

---

## Overheat Protection

- Overheating is extremely rare. If the dehydrator overheats, it will automatically shut down as a safety feature, and will no longer turn on. Contact **Customer Support** (page 14).

## Tips

- Fruit and vegetables dried in your food dehydrator will look different from those sold in stores. This is because homemade dried foods do not use preservatives, artificial coloring, or artificial additives.
- Check out the Recipe Book for many more tips on dehydrating foods.

# CARE & MAINTENANCE

---

**Note:** *Do not clean any part of the dehydrator with abrasive chemicals, as this will damage the surface.*

1. Unplug the dehydrator and allow it to cool before cleaning.
2. If you used a recipe that left traces of liquid or other residue, use paper towels to wipe down the trays before cleaning.
3. Soak trays in hot soapy water for easy removal of food residue.
4. Use a soft brush to clean the trays.

**Note:** *The trays can be washed in the top rack of a dishwasher **only** if you remove them before the drying cycle starts. **Do not** wash the base in a dishwasher. **Do not** immerse the base in water.*

5. Clean the surface of the dehydrator base with a damp cloth.
6. Dry all parts before storing or using the dehydrator.

7. When storing, turn the base upside down and wrap the cord around the center of the base. Secure the cord under the clips. [Figure 2.1]

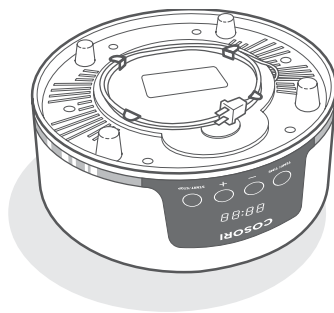

Figure 2.1

8. Set the base back upright and stack the trays on top of the dehydrator as normal.

# TROUBLESHOOTING

---

| Problem  | Possible Solution   |
|--|---|
| <b>The dehydrator will not turn on, or the fan is not working.</b> | Unplug the dehydrator and plug it in again.   |
|  | The dehydrator may be damaged or malfunctioning. Contact <b>Customer Support</b> (page 14).                               |
| <b>“E1”, “E2”, or “E3” appears on the display.</b>                 | The dehydrator may be damaged or malfunctioning. Contact <b>Customer Support</b> (page 14).                               |
| <b>“E4” appears on the display.</b>                                | The dehydrator is being used at a voltage that is too high (such as 220–240V). Unplug and use at a voltage of 120V, 60Hz. |
| <b>Foods are dried unevenly.</b>                                   | Food placed in the lower trays will cook faster. Rotate the trays every few hours.  |
|  | Cut foods evenly to ensure that they all finish drying at the same time.  |
|  | Follow the recipes and tips in the Recipe Book.   |

# FEDERAL COMMUNICATION COMMISSION INTERFERENCE STATEMENT

---

This device complies with Part 15 of the FCC Rules. Operation is subject to the following two conditions:

- (1) This device may not cause harmful interference, and
- (2) This device must accept any interference received, including interference that may cause undesired operation.

NOTE: This equipment has been tested and found to comply with the limits for a Class B digital device, pursuant to Part 15 of the FCC Rules. These limits are designed to provide reasonable protection against harmful interference in a residential installation. This equipment generates, uses and can radiate radio frequency energy and, if not installed and used in accordance with the instructions, may cause harmful interference to radio communications. However, there is no guarantee that interference will not occur in a particular installation. If this equipment does cause harmful interference to radio or television reception, which can be determined by turning the equipment off and on, the user is encouraged to try to correct the interference by one or more of the following measures:

- Reorient or relocate the receiving antenna.
- Increase the separation between the equipment and receiver.
- Connect the equipment into an outlet on a circuit different from that to which the receiver is connected.
- Consult the dealer or an experienced radio/TV technician for help.

**FCC Caution:** Any changes or modifications not expressly approved by the party responsible for compliance could void the user's authority to operate this equipment.

# WARRANTY INFORMATION

|   |                                       |
|---|---------------------------------------|
| <b>Product Name</b>   | <i>Pioneer 5-Tray Food Dehydrator</i> |
| <b>Model</b>  | <i>CFD-N051-W</i>                     |
| For your own reference, we strongly recommend that you record your order ID and date of purchase. |                                       |
| <b>Order ID</b>   |                                       |
| <b>Date of Purchase</b>   |                                       |

## TERMS & POLICY

Arovast Corporation ("Arovast") warrants this product to the original purchaser to be free from defects in material and workmanship, under normal use and conditions, for a period of 2 years from the date of original purchase.

Arovast agrees, at our option during the warranty period, to repair any defect in material or workmanship or furnish an equal product in exchange without charge, subject to verification of the defect or malfunction and proof of the date of purchase.

There is no other express warranty. This warranty does not apply:

- If the product has been modified from its original condition;
- If the product has not been used in accordance with directions and instructions in the user manual;
- To damages or defects caused by accident, abuse, misuse or improper or inadequate maintenance;
- To damages or defects caused by service or repair of the product performed by an unauthorized service provider or by anyone other than Arovast;
- To damages or defects occurring during commercial use, rental use, or any use for which the product is not intended;
- To damages or defects exceeding the cost of the product.

Arovast will not be liable for indirect, incidental, or consequential damages in connection with the use of the product covered by this warranty.

This warranty extends only to the original consumer purchaser of the product and is not transferable to any subsequent owner of the product regardless of whether the product is transferred during the specified term of the warranty.

This warranty does not extend to products purchased from unauthorized sellers. Arovast's warranty extends only to products purchased from authorized sellers that are subject to Arovast's quality controls and have agreed to follow its quality controls.

All implied warranties are limited to the period of this limited warranty.

This warranty gives you specific legal rights and you may also have other rights which vary from state to state. Some states do not allow the exclusion or limitation of incidental or consequential damages, so the above limitation or exclusion may not apply to you.

If you discover that your product is defective within the specified warranty period, please contact Customer Support via [support@cosori.com](mailto:support@cosori.com). **DO NOT** dispose of your product before contacting us. Once our Customer Support Team has approved your request, please return the product with a copy of the invoice and order ID.

Every Cosori product automatically includes a 2-year warranty. To make the customer support process quick and easy, register your product online at [www.cosori.com/warranty](http://www.cosori.com/warranty).

This warranty is made by:

Arovast Corporation  
1202 N. Miller St., Suite A  
Anaheim, CA 92806

# CUSTOMER SUPPORT

---

If you have any questions or concerns about your new product, please contact our helpful Customer Support Team.

**Arovast Corporation**

1202 N. Miller St., Suite A  
Anaheim, CA 92806

**Support Hours**

Mon–Fri, 9:00 am–5:00 pm PST/PDT

**Email:** [support@cosori.com](mailto:support@cosori.com)

**Toll-Free:** (888) 402-1684

\*Please have your order invoice and order ID ready before contacting Customer Support.

# SHOW US WHAT YOU'RE MAKING

---

We hope this manual has been helpful. We can't wait to see your beautiful results, and we think you'll want to share glam shots! Our community awaits your uploads—just pick your platform of choice below. Snap, tag, and hashtag away, Cosori chef!

**#iCookCosori**



**@cosoricooks**



**Cosori Appliances**

Considering what to cook? Many recipe ideas are available, both from us and the Cosori community.

# COSORI®

## **Questions or Concerns?**

Mon - Fri 9:00 AM - 5:00 PM PT

[support@cosori.com](mailto:support@cosori.com) | (888) 402-1684